

**GEARMORE INC.**

# WOOD CHIPPER

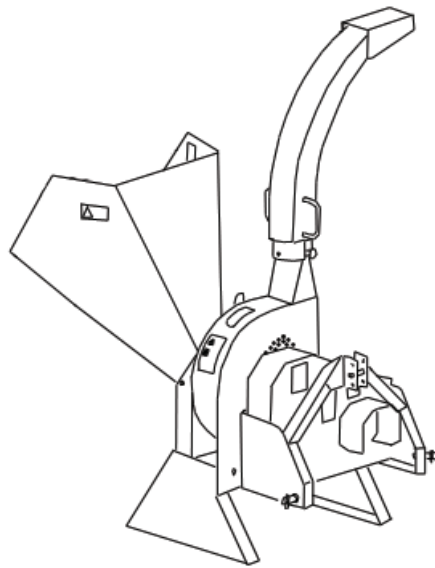

**Operation, Service,  
& Parts Manual  
For Model 420**

June 2008

# TABLE OF CONTENTS

	<b>PAGE</b>
General Information .....	1 - 2
Introduction.....	2
Symbols .....	2
Safety Labels .....	3 - 4
Technical Features.....	5
Terminology.....	6
Main Parts Terminology .....	6
Identification Plate.....	6
Safety .....	7 - 9
Allowed Use.....	7
Improper Use .....	7
Safety in the Workplace.....	7
Operator's Requirements.....	7
General Safety Rules.....	8 - 10
Set-Up .....	11 - 12
Attachment to the Tractor.....	11
Driveline Attachment.....	12
Starting Up.....	12
Feeding System.....	13
Transport & Storage.....	13
Maintenance.....	14 - 19
Maintenance Schedule.....	14
Lubrication.....	15
Blades.....	16 - 17
Belt Tension Check.....	18
Spare Parts Ordering .....	18
Torque Specifications .....	19
Troubleshooting.....	19
Spare Parts.....	20 - 24
Chipper Breakdown.....	20 - 22
Driveline Breakdown.....	23 - 24
Limited Warranty .....	25

# GENERAL INFORMATION



No part of this manual shall be reproduced, copied or disseminated by any means, without Gearmore's prior authorization in writing.

Gearmore reserves the right to make any necessary changes without giving prior notice, in order to optimize the quality and safety features and does not commit itself to updating this manual every time a change is made.

This booklet provides a thorough and accurate description of the instruction and maintenance activities to be carried out on the chipper you purchased. We congratulate you on your choice and urge you to thoroughly familiarize yourself with and follow the instructions contained in this manual. This will assure you a long, safe and trouble free working life for your chipper.

**Gearmore shall not assume any responsibility should problems arise as a result of lack of compliance with the instructions and/or operator's negligence.**

The manual is divided in chapters and paragraphs and the pages are numbered, thus offering accurate and precise information.

The requested information can be easily found by searching the key words or referring to the table of contents.

# GENERAL INFORMATION

## INTRODUCTION:

The Model 420 Chipper was designed to chip branches up to 4 inches in diameter

The chippers are assembled for operation with 540 PTO R.P.M. tractors only (rated PTO up to 45 H.P.) and supplied with Cat. 1 lift pins for tractor attachment.

The chippers can fit Cat. 1 quick attach hitch by using suitable bushings to adapt diameters of lift pins.

## SYMBOLS:

This booklet contains three "safety graphic symbols" which highlight the relevant danger levels or important information:



**It draws the operator's attention to situations which can jeopardize people's safety.**

---



**It draws the attention to situations which jeopardize the machine efficiency but not people's safety.**

---



**It highlights general information which does not endanger people's safety or the efficiency of the parts.**

---

# SAFETY LABELS





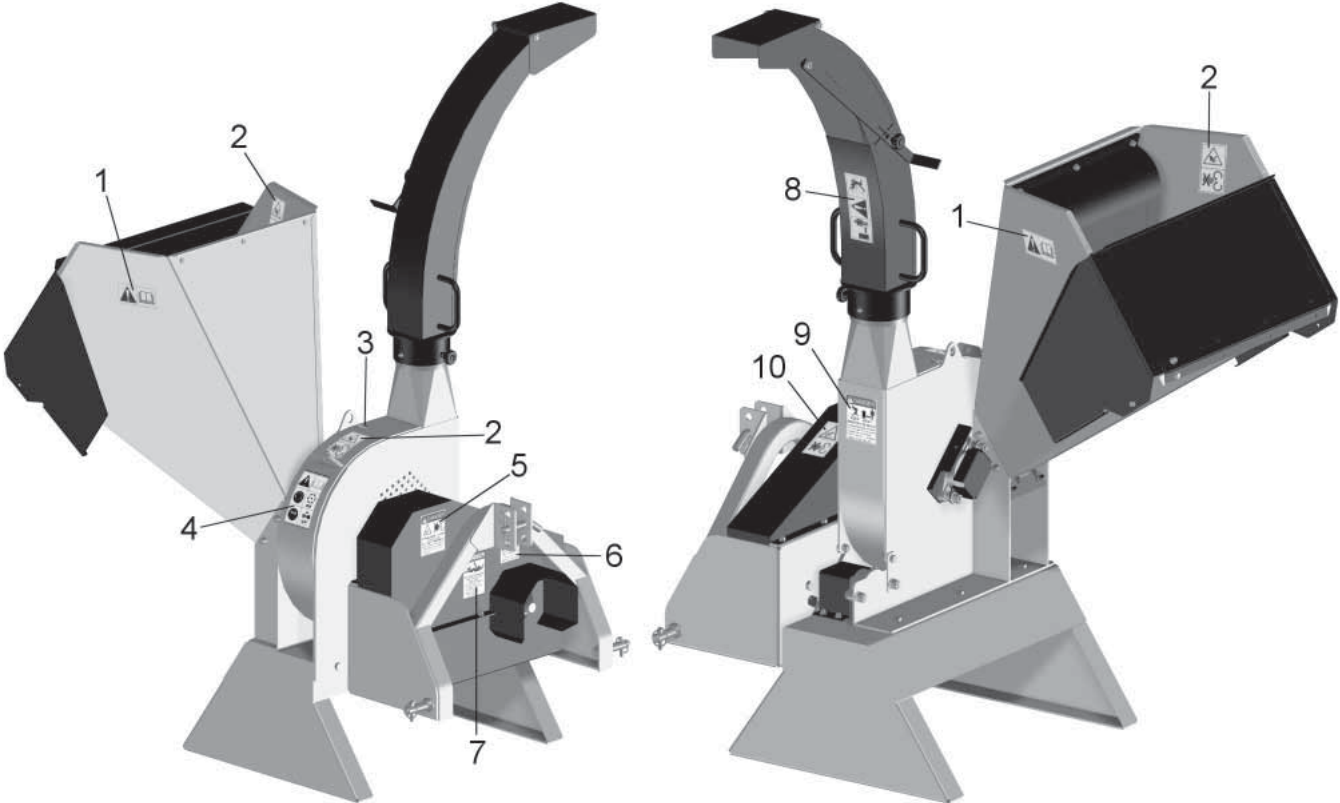





## SAFETY LABELS:

The safety labels and the information on the machine, listed in the following table, must be necessarily carried out; failure to carry out these warnings can cause death or severe injuries. Make sure that the labels are always present and legible, should this not be the case, contact your nearest Gearmore dealer to replace the missing or illegible ones.

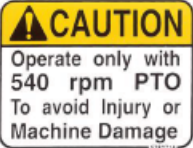

*Note: Shown with optional hopper extension*

# SAFETY LABELS

1		Attention: Read carefully all instructions and safety rules before using the machine.	2		Danger of hands injuries; do not open or remove the safety protections while the machine is operating.
3		Hooking point for the machine's lifting.	4		Attention: Read carefully all instructions and safety rules before using the machine. Stop engine and remove key before maintenance or repair works.  Wear eyeglasses or face guard for eyes and face protection and head guard to protect hearing.
5		ENTANGLEMENT HAZARD To prevent serious injury or death: Do not unbolt or remove safety shields while engine is running	7		ROTATING DRIVELINE Contact can cause death <b>KEEP AWAY!</b> Do not operate without: •All driveline guards, tractor and equipment shields in place •Driveline securely attached at both ends •Driveline guards that turn freely on driveline
6		Operate only with 540 rpm PTO to avoid injury or machine damage.	8		Thrown objects; Keep a safety distance from the machine.
10		Danger of hands injuries: Keep safety guards in position while operating.	9		KEEP AWAY THROWN OR FLYING OBJECTS To prevent serious injury or death: • Do not operate if all safety shields are not installed • Stop machine if anybody comes within 100 feet

**Other Labels:**

# SERIES 420



## TECHNICAL FEATURES

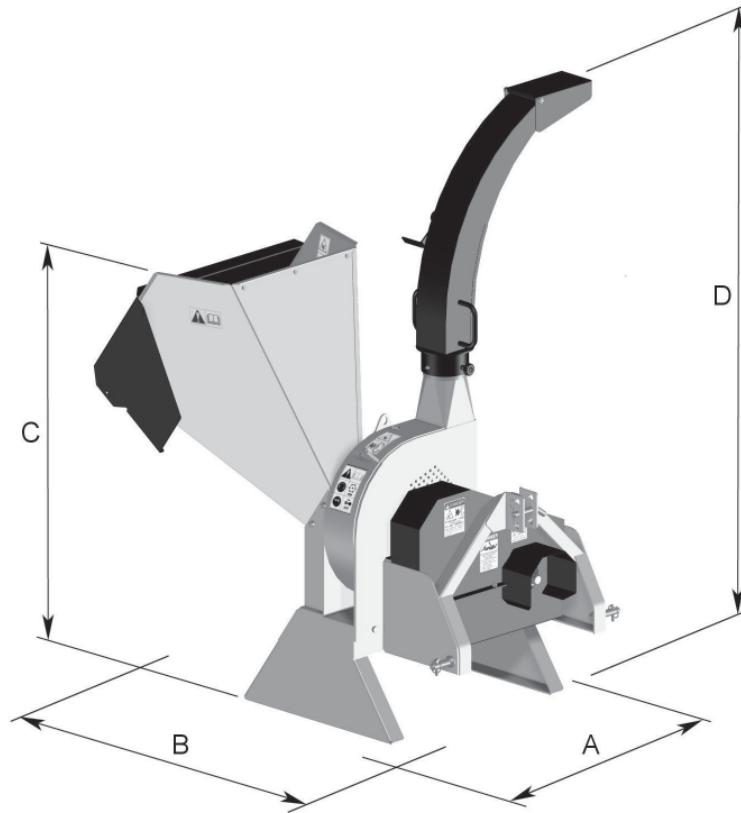

TECHNICAL FEATURES	U.S.	METRIC
A:	45"	1150 mm
B:	50"	1250 mm
C:	57"	1440 mm
D:	76"	1920 mm
Minimum Horsepower Required:	20 H.P.	20 H.P.
Diameter of Material:	4 ½" max.	115 mm
Hopper Dimension - Width x Height:	27" x 24"	700 x 610 mm
Feeding System:	Manual Gravity	Manual Gravity
Feeding Opening - Width x Height:	5 ¾" x 8 ¼"	146 x 210 mm
Number of Blades:	4	4
Flywheel Speed:	1600 rpm	1600 rpm
Knives Tip Speed:	140 ft./sec.	42.3 m/s
Flywheel Weight:	140#	64 kg
Flywheel Diameter:	20"	505 mm
Flywheel Thickness:	1 ¼"	32 mm
3-Point Hitch:	Cat. 1	Cat. 1
Quick 3-Point Hitch:	Cat. 1	Cat. 1
Power Take Off:	540 rpm	540 rpm
Weight:	600#	276 kg

# MAIN PARTS TERMINOLOGY

## MAIN PARTS TERMINOLOGY:

- A Hopper Extension/Cover (Optional)
- B Hopper
- C Chipper Housing
- D Chipper Base
- E Lower 3rd Point Hitches
- F PTO at 540 rpm
- G Upper 3rd Point Hitch
- H Transmission Cover
- I Knives Housing
- L Blower Discharge Tube
- M Exit Deflector
- N Deflector Adjustment

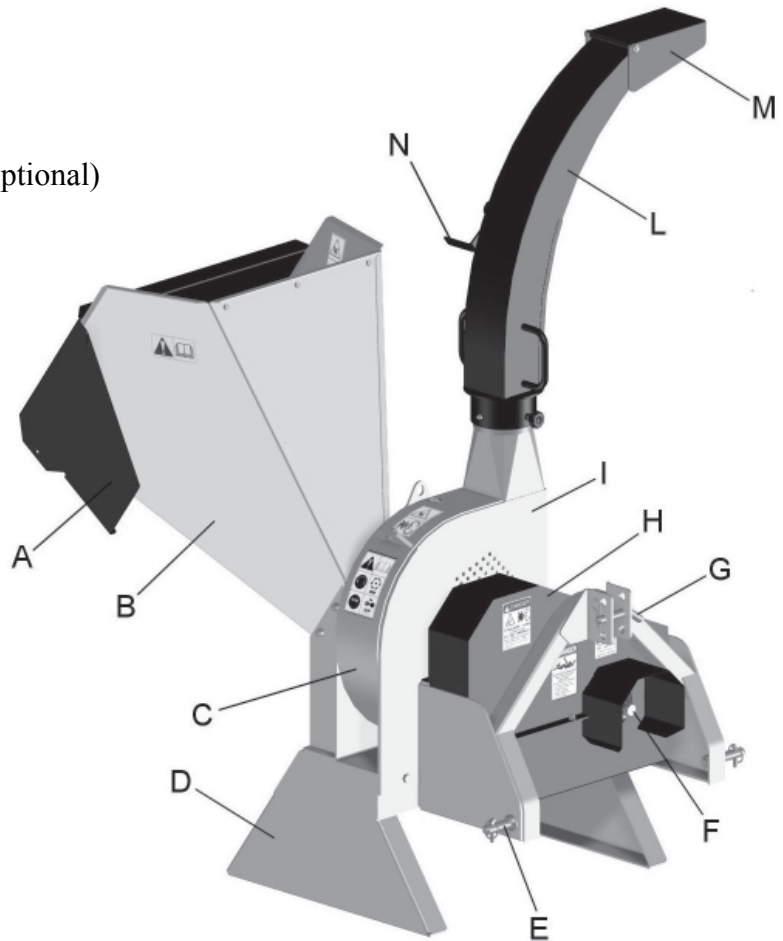

## IDENTIFICATION PLATE

An identification plate is placed on every chipper:



**When asking for information or technical service, always specify the machine type and width.**



# SAFETY

## ALLOWED USE:

Gearmore chippers taken into account in this instruction manual, are equipments designed to chip wood's residuals from pruning and residuals from packaging or from other structures made of wood and free of nails.

Any other use jeopardizes the operator's safety and the machine integrity.

## IMPROPER USE:

When using Gearmore Chippers, it is particularly **forbidden**:

- The attachment to tractors of unsuitable power or weight.
- To assemble the machine without securing the adjustment links of the 3-point hitch of the tractor.
- To chip materials different from wood.
- To introduce pieces of wood of bigger dimensions compared to the machine's capacity.
- To use the machine without having placed the relevant pins and cotter pins where required.
- To lift the machine when the power takeoff is engaged.
- To approach rotating parts when wearing inappropriate work clothing.
- To get on the machine while it is being used or transported.

## SAFETY

### SAFETY IN THE WORKPLACE:

Most of the accidents which take place while the operator is using the machine or the equipment or during their maintenance or repair are caused by a lack of compliance with the basic safety precautions. It is necessary, therefore, to become more and more conscious of the potential risks of one's action by constantly paying attention to one's own actions and their effects.

**If potentially dangerous situations are known, accidents can be prevented!**

### OPERATOR'S REQUIREMENTS:

All operators using the equipment must be competent and necessarily meet the following features:

**Physical:** good eyesight, coordination and capability of carrying out all functions required for the machine's use.

**Mental:** Capable of understanding and applying the established rules and safety precautions. Users must pay attention and be sensible for their own and other people's safety.

**Training:** users must have read and studied this manual, any enclosed graphs and schemes and its identification and danger plates. They must be skilled and trained on any use or maintenance activities.

# SAFETY

## WORK CLOTHING:

When working and especially when executing repair or maintenance activities, it is necessary to wear the following clothing and safety accessories:

- Overalls or other comfortable clothing, not too loose to prevent the possibility that parts of them might be caught in the moving parts.
- Protective gloves for hands.
- Protective glasses or faceplate to protect eyes and face.
- Protective helmet for the head.
- Ear protections to safeguard hearing



**Wear only personal safety accessories in good condition and complying with the rules in force.**

## GENERAL SAFETY RULES

### ALWAYS CONSIDER THE FEATURES OF THE AREA WHERE WORK IS TAKING PLACE:

- Having to attach the equipment on the spot, it is necessary to arrange a flat and compact area of sufficient dimensions.
- When the equipment is running, it is forbidden to stand within the field of action of the chipper or of the other accessories of which it is provided with.

### PREPARE THE WORK:

- Before and when working, do not drink alcohol, take drugs, or any other substances which may alter your capability of working with machine tools.
- Be sure to have sufficient fuel, to prevent a forced stopping of the machine, maybe during a critical movement.
- Do not use the equipment under unsafe conditions. For instance, it is forbidden to execute makeshift repair activities just to start working; it is forbidden to work at night with an insufficiently illuminated working area.

# SAFETY

## **WHEN WORKING OR DURING THE MAINTENANCE ACTIVITIES IT IS NECESSARY TO REMEMBER:**

- The labels and stickers providing instructions and pointing out the dangers, must not be removed, hidden, or made illegible.
- Do not remove, except in case of maintenance, the safety devices and protective covers. When it is necessary to remove them, stop engine, handle with care and reassemble them properly before restarting the engine and using the equipment.
- It is forbidden to lubricate, clean and adjust the moving parts while they are running.
- During maintenance or adjustment activities on the equipment it is forbidden to use hands for executing operations for which there are specific tools.
- Do not use tools in bad condition or inappropriately, for instance pliers rather than wrenches, etc.
- When maintenance or repairs are completed check out that no tools, wiping rags, or other materials are left inside spaces or guides with moving parts.
- While using the equipment, it is forbidden to make more than one person give directions and make signals. The eventual directions and signals relating to the load handling must be given by one person only.
- Do not unexpectedly call an operator while he is working if not necessary; it is forbidden as well to frighten or throw objects at the operator, even if just for fun.
- Watch out for those who are present, especially the children!
- Always make sure that no people stand within the equipment's ray of action.
- Do not make people get on the machine.
- When the equipment is not needed, stop the vehicle's engine, park it on flat ground with first speed and parking brake on, with the machine rested on the ground and PTO disengaged.
- Do not clean, lubricate, repair or adjust with the engine running and the machine lifted.
- Do not stretch your hands into the chipper while it is working.
- Short wooden parts must be pushed towards knives using longer wooden parts or by means of proper pusher device.

# SAFETY

- Small wooden fragments must be pushed in slowly and longitudinally in order to avoid that splinters of wood or other material are thrown against the user.
- Do not use the machine indoors in order to prevent smoke poisoning from the engine combustion.
- Foreign bodies, such as pieces of metal or stones, must be removed before starting the machine.
- Remove protection cover only when the machine is completely stopped from inertia motion and after having disconnected the drive shaft and removed the key from the engine.
- Use the chipper only when wearing proper clothing and after having worn suitable protection for hands, eyes, ears, and head.
- During transporting chipper blower discharge tube must be oriented so that it does not stretch out from the outline of the machine.
- When transporting chipper strictly comply with regulations of the area where you operate.

**The manufacturer declines all responsibility for a lack of compliance with these instructions.**

# SET UP

## ATTACHMENT TO THE TRACTOR

It is advisable to read carefully this Operator's Manual as well as the instruction manuals of the tractor and the PTO shaft manufacturers.

All Gearmore chippers have been manufactured to be attached to any tractor provided with hydraulic lift and universal 3-point hitch.

Before attaching the equipment to the tractor, set both on a flat and smooth ground and make sure that nobody is standing between them.

- Approach slowly the chipper with the arms of the lift and connect first the lower arms and then attach the upper third point hitch. The chipper is equipped with attachment pins of Category 1.
- Make sure you fix the pins with the corresponding klik pins.
- Lock the arms of the lift with proper chains turnbuckle or tensioners.

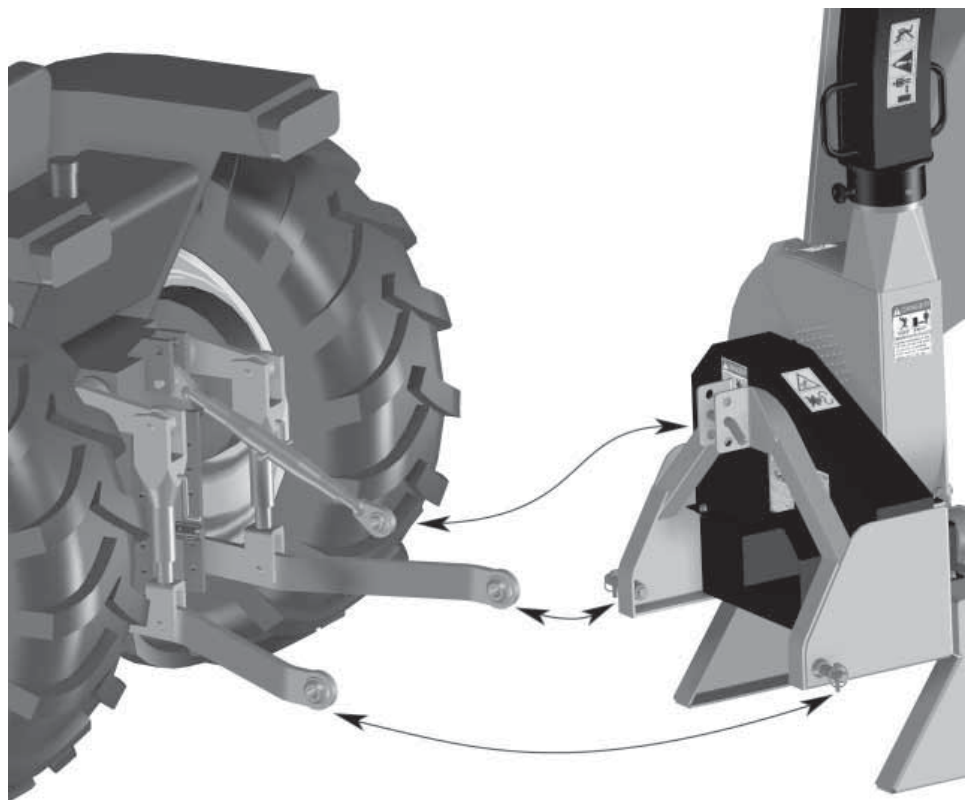

### Caution

After executing the above-mentioned activities it is always good to check that all bolts and nuts of your chipper are tightened strongly (refer to the torque specifications in this manual).

### Caution

Pay attention to the tractor's front wheels grip when the equipment is set up and lifted from the ground; if the wheels appear to be too lightened, ballast the tractor front part.

# SET UP

## DRIVELINE ATTACHMENT

Before assembling the PTO shaft, it is very important to check out that its number of revolutions and direction of rotation match those of the tractor. Also, read carefully the instruction manuals of the PTO shaft and the tractor's manufacturers. Before starting work, check the presence of the safety guards on the power takeoffs of the machine, of the PTO shaft and of the tractor. Check in particular that the safety guards cover the PTO shaft throughout its extension.

### **Caution**

**When at their maximum extension, the safety guards' plastic tubing shall overlap at least 1/3 of their length. When in their maximum closing position, the minimum clearance allowed shall be 3/4" (Fig. 1).**

**Fig. 1**

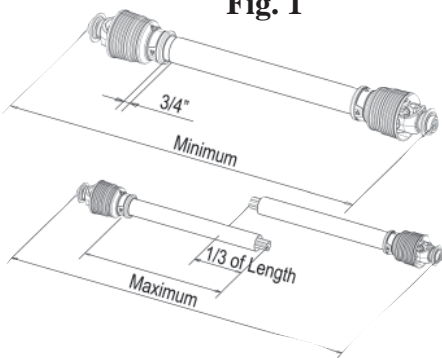

Check out that the PTO shaft minimum and maximum length are the ones required by the machine-tractor coupling. Should problems arise, contact your Gearmore dealer. After installation, secure safety guards both to the tractor and the machine using the special chains and make sure that they pivot freely. If the PTO shaft is equipped with other safety devices, such as a slip clutch, be sure to install them on the working machine side. As for the PTO use and maintenance refer to the relevant booklet.

### **Danger**

**These operations shall be made only on working ground and only after having stopped the engine, disengaged the PTO and pulled the parking brake. If necessary, lift the machine from the ground, but in order to avoid risks for people, place it on supports thus preventing any injuries that might be caused by its sudden fall.**

## CHECKS PRIOR TO STARTING UP

Before starting the chipper check the following:

- ▶ The machine is properly connected.
- ▶ It is firmly rested on the ground.
- ▶ The chipper is parallel to the ground in order to avoid major stress on the PTO.
- ▶ The knives are sharpened.
- ▶ The discharge tube is correctly mounted and positioned.

## STARTING UP OF THE CHIPPER

When all setting up operations are completed, your machine is ready to be used. At this point it is possible to engage the PTO and work the machine at full capacity.

# SET UP



Use the power take off only at 540 rpm.

## MATERIAL FEEDING SYSTEM AND CHIPPING

Before starting to chip make sure the unit has reached 540 rpm PTO speed.

- After having correctly oriented the blower discharge tube, open the hopper cover.
- Accurately select the wooden material to be chipped and do not exceed the maximum cutting diameter of 4 ½".
- Small branches can be kept together and put in simultaneously with their butt end turned towards the entrance.
- **Absolutely avoid pushing the branches down the hopper slide using your hands.** Use other pieces of wood and if necessary, use proper pusher device.



Before putting parts to be chipped into the hopper, remove parts different from wood so that knives are not damaged.

## ROAD TRANSPORT

While transporting the machine it is very important to follow the road traffic code of the area where you operate.

## SET ASIDE / STORAGE

If the chipper will not be used for a long period of time, we advise to:

1. Wash the machine accurately and dry it.
2. Check out all equipment and replace damaged or worn parts.
3. Tighten strongly all bolts and nuts (See torque specifications chart).

Make an accurate greasing and at last protect the whole machine with a tarpaulin in a building. Store it in a dry place. Following the instruction will allow you to find the chipper always in good conditions whenever you use it.

# MAINTENANCE

Maintenance is a fundamental operation to extend life and performances of any agricultural implement; taking care of the machine grants you not only a good work condition, but also a longer life of the equipment and greater safety in the workplace.

The operating times indicated in this manual have just an informative character and are referred to normal conditions of use; they can thus undergo variations according to the type of service, to the more or less dusty environment, to seasonal factors, etc.

## MAINTENANCE SCHEDULE

### EVERY 10 HOURS OF WORK

---

- At the end of every working day it is advisable that you clean accurately the machine so that its parts are always in good working condition.
- Grease crosses on the PTO shaft.
- Make a general inspection to verify possible hydraulic oil leaks or the presence of damaged parts, when it applies.
- Make sure the knives are in good condition, sharpened and perfectly fixed by the tightening bolts.

### EVERY 25 HOURS OF WORK

---

- Grease the driveshaft crosses through the special lubricating zerks.
- Grease the transmission shaft through the proper lubricating zerks.

### EVERY 50 HOURS OF WORK

---

- Check to make sure that the belts are tightened.
- Check that all bolts and nuts are correctly tightened.

## MAINTENANCE INTERVENTIONS

---



**Before executing maintenance activities on the machine, stop engine, disengage PTO, pull parking brake, and place the equipment on the ground in horizontal position.**

---



# MAINTENANCE

## Caution

Before injecting lubricating grease into the zerks, clean them accurately to prevent mud, dust, or other foreign matters from mixing with the grease, thus diminishing the lubrication effect.

## GREASING

Lubricate the machine regularly with a high quality lithium based grease to keep it efficient and extend its life and performance.

Grease the following areas every 25 hours or sooner, if operated in extreme conditions; taking care to not over grease bearings which could damage the seals.

- A, B (Picture 1) Transmission shaft supports.
- C, D (Picture 2 - 3) Flywheel shaft supports.
- E (Picture 4) Blower discharge tube base.

Picture 1

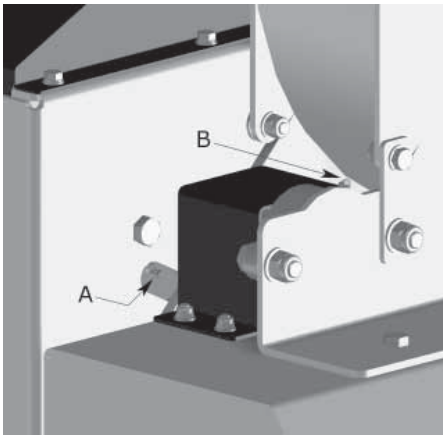

Picture 2



Picture 3

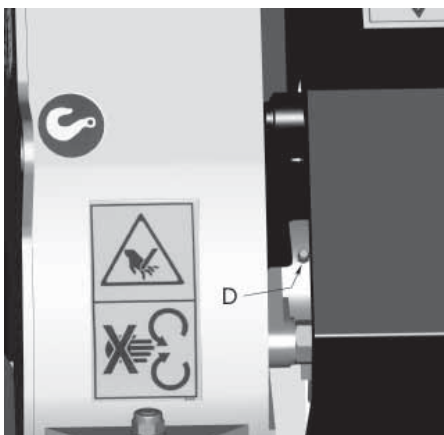

Picture 4

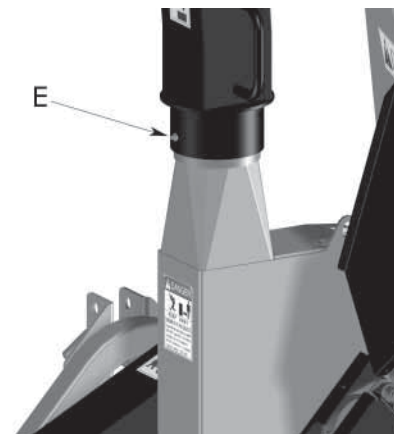

# MAINTENANCE

## BLADES CHECK

To assure a perfect functioning of the chipper check often that its blades are in good conditions, sharpened and perfectly fixed by the locking bolts.

To inspect the rotor and the blades condition, please proceed as described below:

- Stop the machine.
- Disengage the PTO shaft and remove the tractor ignition key.
- Remove the locking screw of the flywheel housing.
- Grab the top half of the housing by the handles and slowly open the cover to maximum open position.
- Carefully rotate the flywheel checking the condition of every single blade.

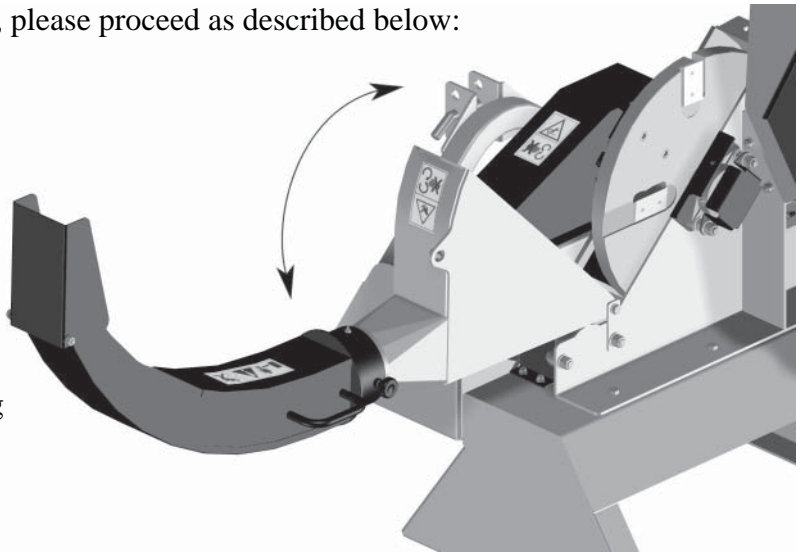

## SHARPENING AND REPLACEMENT OF BLADES

A poor performance of the chipper usually depends on its blades wear.

To disassemble the blades, please proceed as follows:

- Repeat previous point regarding check.
- Rotate flywheel until blade screws are accessible.
- Remove fixing screws and pull out the blade.
- Sharpen or replace the blades.
- Install the new blades with the hardware that was included.
- Repeat operation for the remaining blades.

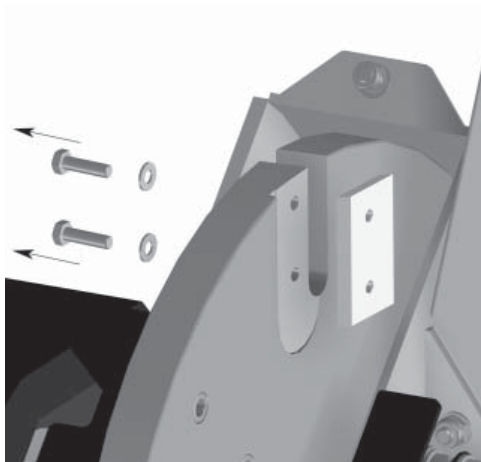

# MAINTENANCE

If the blades are worn, you should then proceed with their sharpening.

In case blades are particularly worn or damaged, replace them with genuine Gearmore blades.

Fig. 5

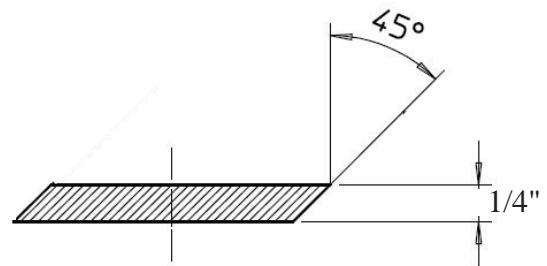

**Blade sharpening must be done with suitable machines that can guarantee a correct sharpening to insure the angle indicated (Fig. 5).**

Every time blades are removed (disassembling/reassembling), before starting the machine again, it is advisable to check and adjust the distance between blade and bed knife. To adjust bed knife position proceed as follows;

- Loosen locking screws (4).
- Rotate the rotor (1) bringing the blades (2) near the bed knife (3).
- Adjust the position of the bed knife (3) by means of adjusting nuts (5) making sure that distance between blade and bed knife is included between .063 and .126.
- Make sure that this distance is the same for all blades.
- Block adjusting nuts (5) and tighten locking screws (4) with a torque wrench per the torque specification chart.

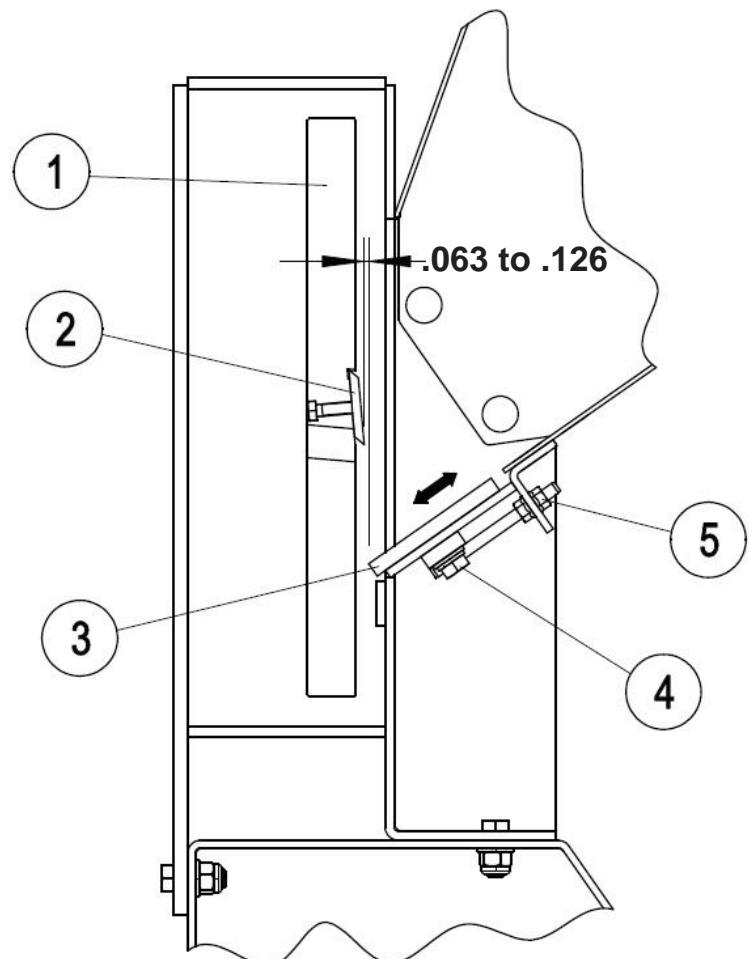

# MAINTENANCE

## BELT TENSION CHECK

Belts have an automatic spring tensioner and need a check on the condition of springs.

To increase or decrease tension of belts proceed as follows:

- Stop the machine.
- Disengage the PTO shaft and remove tractor ignition key.
- Take off screws of the two transmission covers, upper and lower.
- Remove the two covers.
- Adjust on the nuts (A) of rod (B) which is threaded to stretch or extend the spring (C) with a power of 20 lb. (9kg).
- If the spring is slackened, it is necessary to replace it; first it is necessary to disassemble the threaded rod.
- Block the rod washers.
- Reassemble the two transmission covers and tighten the relevant screw

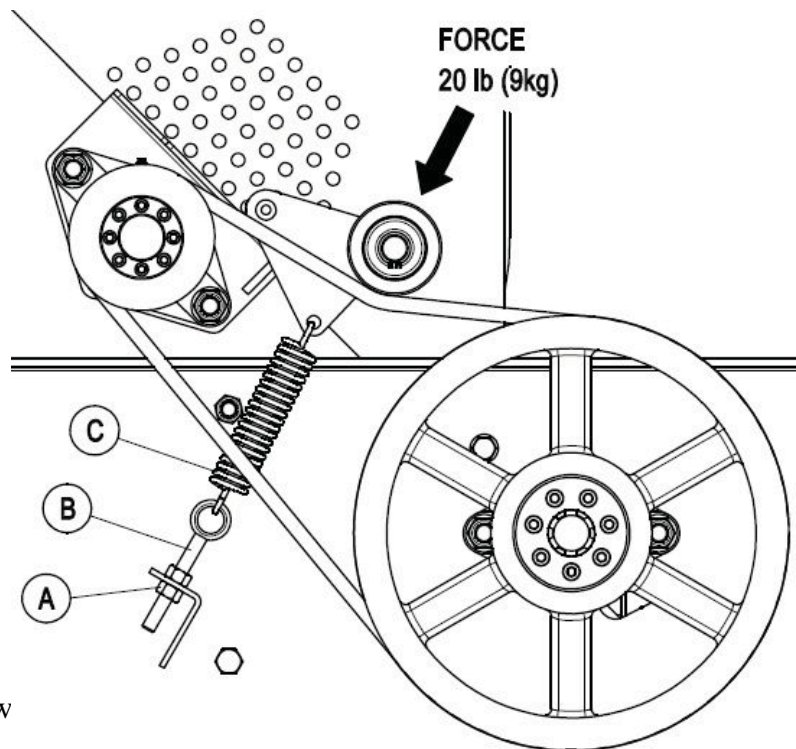

## SPARE PARTS ORDERING

To order spare parts, please see parts section in this catalog.

Request of spare parts must be made to a Gearmore dealer and must always be complete with the following information:

- Type and width of the implement.
- Part number of the needed spare part. If not in possession of this number, you can replace it with the number of the table where the part is represented and the correspondent reference.
- Denomination of the needed part and desired quantity.

# MAINTENANCE

## TORQUE SPECIFICATIONS

For correct hardware tightening on the Chipper, we suggest the use of a suitable torque wrench and the applicable torque as listed in the table.

<b>M-THREADED SCREW / BOLTS</b>				
<b>Bolt Grade</b>				
<b>Thread</b>	<b>8.8</b>		<b>10.9</b>	
	<b>Nm</b>	<b>lb / ft</b>	<b>Nm</b>	<b>lb / ft</b>
M6	11	8.5	17	12
M8	28	20	40	30
M10	55	40	80	60
M12	95	70	140	105
M14	150	110	225	165
M16	240	175	305	225
M18	330	250	475	350

## TROUBLESHOOTING

<b>PROBLEM</b>	<b>POSSIBLE CAUSE</b>	<b>REMEDY</b>
Not chipping cleanly or flywheel plugging.	Dull knives.	Sharpen or replace knives.
	Bed knife dull or rounded.	Sharpen or reverse bed knife.
	Bed knife not adjusted properly.	Adjust to clearance of .063 to .126
Unit will not feed.	Limb forks too wide.	Remove from hopper and trim off forks.
Chipper requires excessive power or stalls.	Plugged flywheel.	Clear flywheel, then feed material more evenly.
	Obstructed discharge.	Clean out discharge chute.
	Improper blade clearance.	Adjust clearance of bed knife.
Chipper vibrates.	Material balled up on flywheel.	Clean flywheel with putty knife or other tool.
	Broken or loose part.	Access flywheel and repair what is required.
Chipper RPM slows, but tractor RPM does not.	Drive belts are slipping	Tighten belts. Replace
	Dull knives.	Sharpen or replace knives.
Excessive belt wear.	Belt tension too loose.	Replace belts or spring.
	Pulleys not in alignment.	Align pulleys with straight edge.
	Pulleys damaged or worn.	Replace pulley or pulleys in question.
Rotor will not turn.	Plugged rotor.	Clear rotor then feed material more evenly.
	Obstructed discharge.	Clean discharge chute.
	Drive belts loose or broken.	Replace belts and/or spring.

# PARTS BREAKDOWN

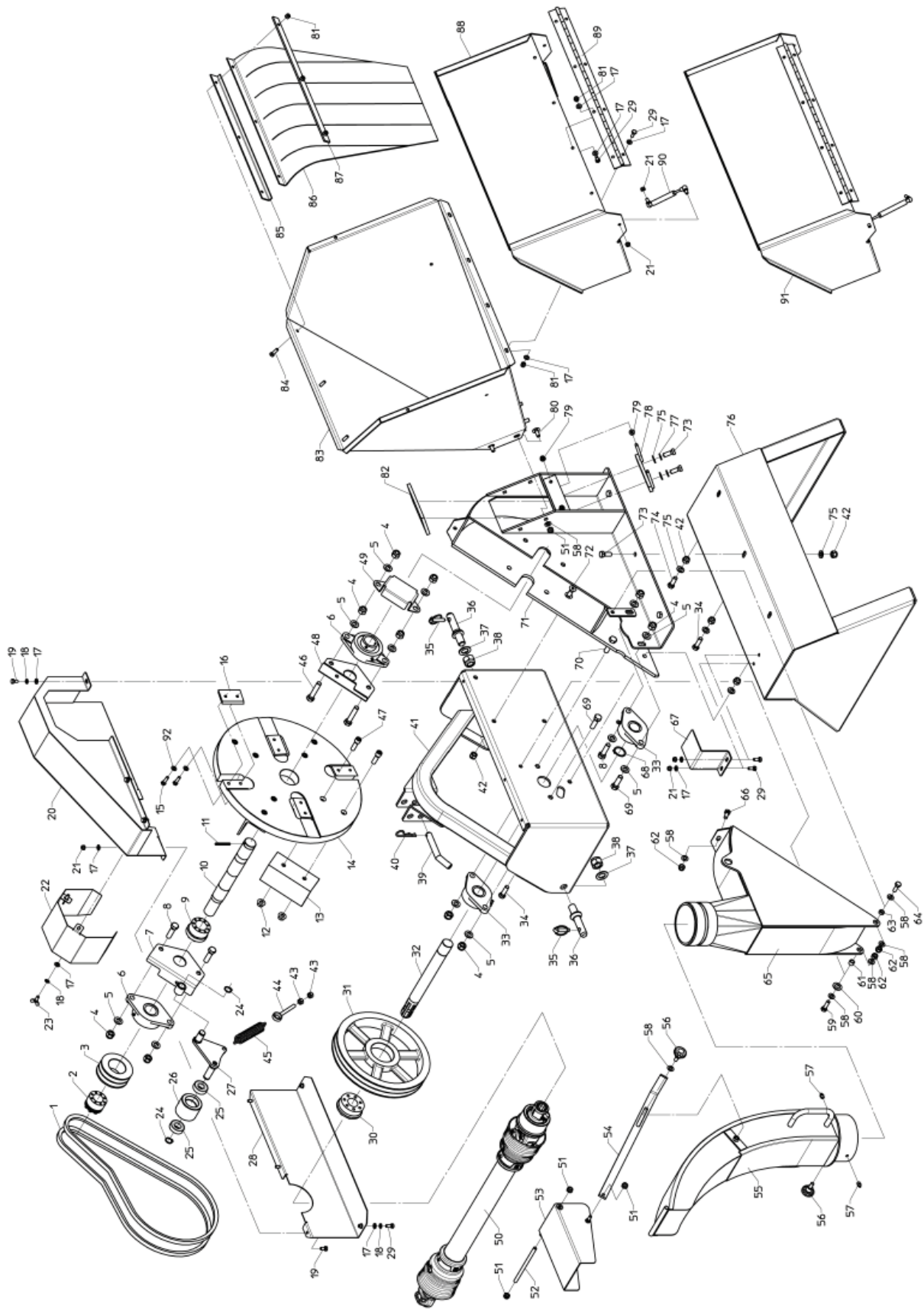

# PARTS LIST

<u>REF.</u>	<u>QTY.</u>	<u>PART NO.</u>	<u>DESCRIPTION</u>
1	2	6721057	Belt BX-57
2	1	6363560	Tapered Locking Unit VK 700 35/60
3	1	5642901	Drive Pulley BX100 x 2
4	10	34106014	Stop Nut M14 x 2 DIN 982 6
5	12	34120014	Washer UNI 6592 M14
6	2	2020040	Bearing UCFL/208
7	1	5002906	Tensioner Belt Support
8	3	31514050	Screw UNI 5739 M14 x 50 8.8
9	1	6384065	Tapered Locking Unit VK 700.1 40/65
10	1	5402900	Drive Pulley Shaft
11	1	6330655	Elastic Pin UNI 6873 6 x 55
12	8	34129012	Stop Nut M12 x 1.75 DIN 6927 8
13	4	5852900	Flywheel Blade
14	1	5932900	Blade Disk
15	8	31508030	Screw UNI 5739 M8 x 30 8.8
16	4	5812900	Chipper Blade
17	28	34120008	Washer UNI 6592 M8
18	7	34121008	Washer UNI 1751 M8
19	6	31508016	Screw UNI 5739 M8 x 16 8.8
20	1	5002908	Upper Transmission Cover
21	7	34108008	Stop Nut M8 DIN 985 6
22	1	5132916	PTO Shield
23	2	33108020	Wing Screw M8 x 20 UNI 5449
24	2	6320020	Circlip External D20 DIN 471
25	2	2226204	Bearing 6204 2RS
26	1	5782901	Tensioning Roller
27	1	5002907	Belt Tensioner
28	1	5132917	Lower Transmission Cover
29	12	31508020	Screw UNI 5739 M8 x 20 8.8
30	1	6363580	Tapered Locking Unit VK 156 35/80
31	1	5642900	Drive Pulley BX315 x 2
32	1	5302901	Drive Pulley Shaft
33	2	2020035	Bearing UCFL/207
34	2	31512040	Screw UNI 5739 M12 x 40 8.8
35	2	6350010	Release Pin D.10
36	2	5302900	Pin, 3rd Lower Point
37	2	34120022	Washer UNI 6592 M22
38	2	34106022	Stop Nut M22 DIN 982 6
39	1	4301589	Pin, Upper 3rd Point
40	1	6351004	Cotter Pin D.4
41	1	5002905	3 Point Hitch
42	9	34106012	Stop Nut UNI 7473 M12
43	2	34100010	Nut UNI 5587 M10
44	1	33710096	Screw M10 L=96
45	1	5215701	Belt Tensioner Spring
46	2	31514070	Screw UNI 5739 M14 x 70 8.8

## PARTS LIST

<u>REF.</u>	<u>QTY.</u>	<u>PART NO.</u>	<u>DESCRIPTION</u>
47	8	31712040	Screw M12 x 40 UNI 5931 8.8
48	1	5132905	Bearing UCFL Support
49	1	5132926	Bearing UCFL Shield
50	1	EAX47048-8007	AX4 480/733 1024010-1504260 CP SS
51	9	34108010	Stop Nut M10 DIN 985 6
52	1	5332136	Deflector Tie Rod
53	1	5002134	Deflector
54	1	5832138	Deflector Adjusting Lever
55	1	5002073	Exit Chute
56	2	6601020	Knob M10 X 20
57	2	6560010	Grease Nipple M10 x 1.5 UNI 7663-A
58	12	34120010	Washer UNI 6592 M10
59	1	31510035	Screw UNI 5739 M10 x 35 8.8
60	1	34120016	Washer UNI 6592 M16
61	1	5532902	Bushing
62	3	34106010	Stop Nut UNI 7473 M10
63	1	5532901	Bushing
64	1	31510030	Screw UNI 5739 M10 x 30 8.8
65	1	5002904	Chipper Cover
66	1	31510025	Screw UNI 5739 M10 x 25 8.8
67	1	5132901	Shaft Shield
68	1	6320035	Circlip External f35 DIN 471
69	2	31514045	Screw UNI 5739 M14 x 45 8.8
70	1	31514055	Screw UNI 5739 M14 x 55 8.8
71	1	5002901	Chipper Box
72	2	31912035	Screw UNI 5933 M12 x 35 8.8
73	5	31512030	Screw UNI 5739 M12 x 30 8.8
74	1	31512035	Screw UNI 5739 M12 x 35 8.8
75	8	34120012	Washer UNI 6592 M12
76	1	5002900	Chipper Support
77	2	34121012	Washer UNI 1751 M12
78	1	5002902	Knocker Tie Rod
79	4	34129008	Stop Nut M8 x 1.25 DIN 6927 8
80	6	33010025	Screw UNI 5731 M10 x 25
81	11	34106008	Stop Nut UNI 7473 M8
82	1	5832902	Knocker
83	1	5002910	Chipper Chute
84	3	31508025	Screw UNI 5739 M8 x 25 8.8
85	1	5132927	Anchor Angular
86	1	5782900	Chute Protection
87	1	5832906	Anchor Plate
88	1	5002911	Chute Cover (Optional)
89	1	5002909	Cover Hinge
90	1	6615624	Gas Spring
91	1	8855001	Chute Cover Kit (Optional)
92	8	34026008	"Schnorr" Washer M8



# DRIVELINE

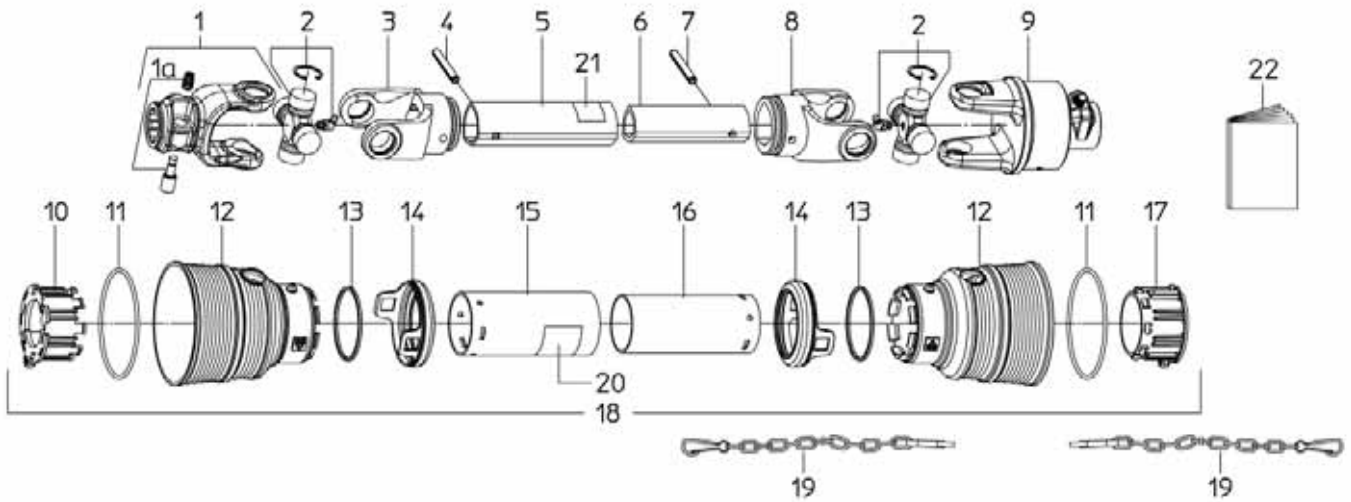

<u>REF.</u>	<u>QTY.</u>	<u>PART NO.</u>	<u>DESCRIPTION</u>
1	1	1024010	Yoke Assembly (Tractor End)
1A	1	1581038	Push Pin Kit
2	2	1004020	Cross Assembly
3	1	1704027	Outer Tube Yoke
4	1	6330860	Roll Pin 8 x 60 DIN 1485 (Outer Tube)
5	1	1524034	Outer Tube
6	1	1525034	Inner Tube
7	1	6330855	Roll Pin 8 x 55 DIN 1485 (Inner Tube)
8	1	1704029	Inner Tube Yoke
9	1	1504260	Safety Device; Free Wheel
10	1	1784710	Tube Bearing (Outer Tube)
11	2	1211733	Stiffening Ring
12	2	1781723	Soft Standard Cone
13	2	1211735	Safety Ring
14	2	1881709	Safety Sleeve
15	1	1773026	Outer Tube Shield
16	1	1872026	Inner Tube Shield
17	1	1784711	Tube Bearing (Inner Tube)
18	1	96SS4026	Complete Protection
19	2	1006065	Anti-Rotation Chain
20	1	1140001	Outer Decal
21	1	1140003	Inner Decal
22	1	1140910A	User Manual

# DRIVELINE - SAFETY DEVICE

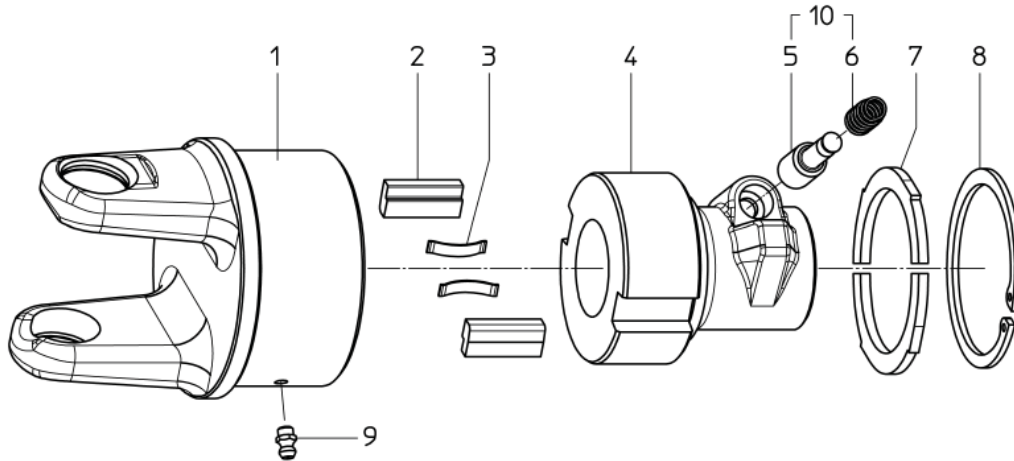

<u>REF.</u>	<u>QTY.</u>	<u>PART NO.</u>	<u>DESCRIPTION</u>
1	1	1504240	Outer Body for RF1/4
2	2	1326062	Key
3	2	1215001	Flat Spring
4	1	1506132	Hub 1 3/8" Z6
5	1	1706016	Push Pin
6	1	1215016	Push Pin Spring
7	2	1133011	Closure Ring
8	1	6320075	Elastic Ring
9	1	6560006	Grease Zerk
10	1	1581038	Push Pin Kit

# LIMITED WARRANTY



GEARMORE, INC., warrants each new Gearmore product to be free from defects in material and workmanship for a period of twelve (12) months from date of purchase to the original purchaser. This warranty shall not apply to implements or parts that have been subject to misuse, negligence, accident, or that have been altered in any way.

Our obligation shall be limited to repairing or replacement of any part, provided that such part is returned within thirty (30) days from date of failure to Gearmore through the dealer from whom the purchase was made, transportation charges prepaid.

This warranty shall not be interpreted to render us liable for injury or damages of any kind or nature, direct, consequential or contingent, to person or property. This warranty does not extend to loss of crops, loss because of delay in harvesting or any other expenses, for any other reasons.

Gearmore in no way warrants engines, tires, or other trade accessories, since these items are warranted separately by these respective manufacturers.

Gearmore reserves the right to make improvements in design or changes in specification at any time, without incurring any obligations to owners or units previously sold.

GEARMORE, INC.  
13477 Benson Ave.  
Chino, CA 91710

Always refer to and heed machine operating warning decals on machine.

*The serial number of this product is stored in our computer database, thus submitting a warranty registration card is not required.*

## CUSTOMER INFORMATION

NAME: \_\_\_\_\_

PURCHASED FROM: \_\_\_\_\_

DATE OF PURCHASE: \_\_\_\_\_

MODEL NUMBER: \_\_\_\_\_

SERIAL NUMBER: \_\_\_\_\_