



COLLARD®

LEAF REMOVERS

EFFECTIVE ONE PASS SYSTEM FOR REMOVING LEAVES AROUND THE FRUIT ZONE



Effective leaf removing to aid in ripening, color intensity and removing any impurities. The leaf removal is achieved by our “patented” double flow low pressure air produced by the 3 point PTO driven air compressor. The Collard system blows through the leaves at fruit level by rotating nozzles that removes the leaves from both the outside and interior of the row, achieving selective leaf removal around the apples without damage.

Marketed By:



13477 Benson Ave. • Chino, CA 91710

Ph: 909/548-4848 • Fax: 909/548-4747

www.gearmore.com • sales@gearmore.com



COLLARD

LEAF REMOVERS FOR APPLES

FEATURES:

- **ELLIPSE-MULTIROTOR**® dual rotor defoliation heads “patented”
- Requires only one pass for total leaf removing
- Unique system for selecting the air nozzle speed for your desired leaf removal requirements
- Special thin line heads, 3 ½ inches wide to easy enter in the foliage
- Hydraulic cylinder for adjusting heads up and down 23.6 inches
- Hydraulic cylinder for adjusting heads in and out 17.7 inches
- Hydraulic cylinder for adjusting heads from perpendicular to 10 degrees right or left
- Manual/hydraulic angle adjustments up to 28 degrees
- Manual adjusting of heads heights
- Counterweight to add stability to the defoliation heads
- 3 point hitch, PTO driven air compressor with special prefiltration and ventilation kit
- Joystick controls from tractor
- Special reinforced frame to adjust the main beam of the defoliation heads
- Top mounted curved bracket to lift netting to insure leaf remover clearance
- Tractor mounting bracket is included
- The Leaf Removers come with all hoses, fitting, and JIC couplers
- Special storage stand for parking Leaf Removers

Note: The tractor requirement with hydraulic capacity of 6.6 G.P.M. at 2320 PSI.

Your **COLLARD**® Dealer



**3 Point hitch mounted
PTO driven air compressor**

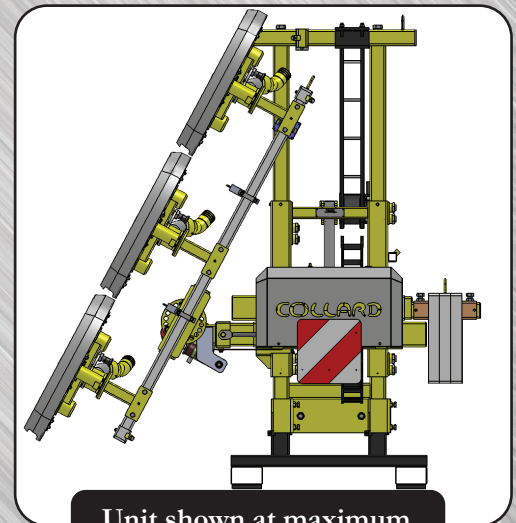

**Unit shown at maximum
tilt of 28 degrees**

SPECIFICATIONS:

Order Code	Model Number	Description	No. of Heads	Working Length	Weights	
					Front Unit	Rear Unit
0411 1200	E1100FA2	Leaf Remover	2	55"	1190#	1080#
0411 1300	E1100FA3	Leaf Remover	3	83"	1240#	1080#

Specifications Subject To Change Without Notice

13477 Benson Ave. • Chino, CA 91710 • Ph: 909/548-4848 • Fax: 909/548-4747